

### SOCKET WELD ELBOW

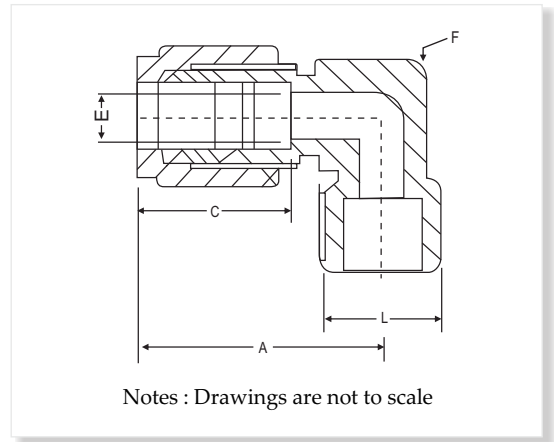

### Dimensional Details :



Dimension, in.

Tube OD	Part Number	A	C	E	F	L
1/4	K4SWE4	1.06	0.60	0.19	1/2	0.50
3/8	K6SWE6	1.20	0.66	0.28	5/8	0.62
1/2	K8SWE8	1.42	0.90	0.41	13/16	0.81
3/4	K12SWE12	1.57	0.96	0.62	11/16	1.06
1	K16SWE16	1.93	1.23	0.88	13/8	1.38

### SOCKET WELD CONNECTOR



### Dimensional Details :

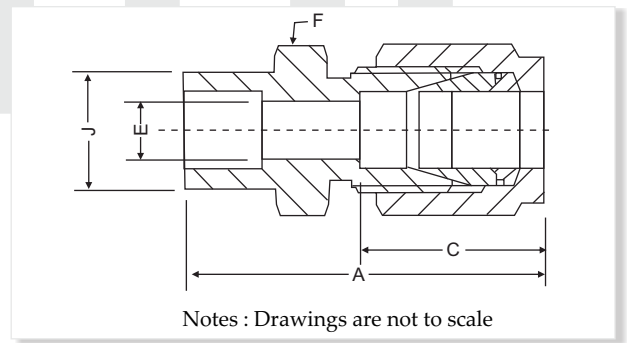

Dimension, in.

Tube OD	Male Pipe Weld Size	Part Number	A	C	E	J	F
1/4	1/4	K4SWC4	1.49	0.60	0.19	0.540	9/16
3/8	3/8	K6SWC6	1.57	0.66	0.28	0.675	11/16
1/2	1/2	K8SWC8	1.93	0.90	0.41	0.840	7/8
3/4	3/4	K12SWC12	1.99	0.96	0.62	1.050	11/16
1	1	K16SWC16	2.45	1.23	0.88	1.315	13/8

Dimension, mm.

Tube OD	Male Pipe Weld Size	Part Number	A	C	E	J	F
6	1/4	KM6SWC4	37.9	15.3	4.8	13.7	14
8	1/4	KM8SWC4	38.7	16.2	6.4	13.7	15
8	1/2	KM8SWC8	45.6	16.2	6.4	21.3	22
10	3/8	KM10SWC6	40.9	17.2	7.9	17.1	18
10	1/2	KM10SWC8	46.5	17.2	7.9	21.3	22
12	1/2	KM12SWC8	49.0	22.8	9.5	21.3	22
16	1/2	KM16SWC8	49.0	24.4	12.7	21.3	24

**Note:**

- A and C dimensions are typical finger-tight

Dimensions and specifications shown are approximate, may vary from time to time.

Ventil tube fittings are ordered by part numbers as listed in this catalogue and other sizes will be available on request.